



EVALUATION OF THERMAL EFFICIENCY FOR SOLAR ENERGY STORAGE OF AGRICULTURAL PRODUCTS: A REVIEW

Hussein Abbas Jebur*, Ahmed Khudhayer Jabr* and Suhad Yasin Jassim¹

*Department of Agricultural Machines and Equipment, College of Agriculture, University of Baghdad, Iraq.

¹Iraq Natural History Research Center and Museum, University of Baghdad, Iraq

Abstract

Solar energy is considered one of the most important renewable energies where it does not need to exert effort to extract it. The solar drying of agricultural products is one of the most important applications of using solar energy. Using of modern technologies in the design of vegetable and fruit dryers has increased. However, this industry still faces many problems. Sun doesn't continue to shine during the night or in the clouds. This review presents feature of solar energy and their applications in different agricultural Production are of substantial importance and a contestation to researchers and scientific research, one of the main problems of using solar energy is that the sun available in large quantities on the day and ends when the sun sets so you must store the solar energy during the day and then be-used during the night. In order to take advantage of solar energy during the night has been adopted several ways to store solar energy during daylight hours and the most important of these methods are using different types of solid materials, for example *Basalt, Sand and Gravel*. The effect of solid materials treatments on storability of solar energy is reviewed herewith, which may help to the researchers in planning their experiments about "solar energy" more useful and in right direction to get more accurate results. Renewable energy audits aim to provide information, data and readings to researchers and stakeholders in renewable energy for years to come.

Key words: Thermal efficiency, solar storage, agricultural products

Introduction

At the present time, solar energy is more attractive than ever as alternative energy resource which can provide heating, cooling and hot water at economically competitive costs and without environmental hazard. Because of the desirable environmental and safety aspects of solar energy, it is advisable to replace of nuclear or fossil energy even when its costs are slightly higher. However, there is problem in using solar energy which can only be collected during daylight hours and sunny days. Thus, some provision must be made for storage to accommodate night time and cloudy-days demand, but all these disadvantages are outweighed by the twin benefit of the universality of the source and long term economy of operating a solar energy system (Ghoniem and Gemea, 2014). The use of the sun in the drying of agricultural products is the old way in most countries especially the third world countries. Sun drying displays an affordable method of drying, but often results to inferior quality of

products due to its dependence of weather conditions and vulnerably to the attack of dust, dirt's, rains, insects, and microorganism (Esper and Muhlbauer 1998). Solar-powered drying is better than traditional methods and it has been developed for various agricultural products. Solar energy for yield drying is Eco friendly and economically applicable in the developing countries (Aktas *et al.* 2016, Gulcimen *et al* 2016, Kant *et al.* 2016, Schirmer *et al* 1996, Misha *et al.* 2016 and Ziafroughi and Esfahani 2016). Solar energy reaches our planet a lot Greater than the needs of our civilization. The main obstacle on the way to its wider use is high variability. This fact determines the need to provide a way to store the energy for the time when the Sun is not shining over particular region or the radiation is not sufficient (Kapica, 2017). In a study by (Gemea, *et al.* 2012) the amount of hourly heat stored in at thickness 60 cm was higher than at thicknesses 40 and 20 cm. Basalt is superior to sand and gravel by giving the best results in each case, the amount of hourly heat stored in basalt at thickness 60 cm was higher than at thicknesses 40 and 20 cm. by 4.83 and 15.8% respectively,

*Author for correspondence :

when the storage units are closed during daylight. And by 7.4 and 25.6% respectively, when the storage units are open during daylight. Duansheng *et al.* (1991), studied experimentally the thermal efficiency of the walls of two different types of the greenhouses. The first type wall of the greenhouses was built by rammed earth with 0.50m thickness and that second type of greenhouses held the vacancy interlayer brick wall. From inside room to outside room with brick of 0.12m, vacancy interlayer 0.12m and 0.24 brick respectively. Gil *et al.* (2010) cited that sensible thermal energy storage consists of a storage medium, a container commonly tank and inlet/outlet devices. Tanks must both retain the storage material and prevent losses of thermal energy. The existence of a thermal gradient across storage is desirable. Sensible heat storage can be made by solid media or liquid media. Solid media are usually used in packed beds, requiring a fluid to exchange heat. When fluid is a liquid, heat capacity of the solid in the packed bed is not negligible, and the system is called dual storage system. Packed beds favor thermal stratification, which has advantages. An advantage of dual system is the use of inexpensive solids such as rock, sand or concrete for storage material. Oztutk and Bascetincelik (2003) reported that the solid materials were economically more attractive for high temperature heat storage than fluids and their volume requirement were nearly comparable. Direct contact between the solid storage medium and heat transfer fluid was vital to minimize the cost of heat exchange in a sensible heat storage system. The charging and discharging process

of a thermal energy storage system was recommended to be analyzed in order to optimize the system efficiency. The choice of storage medium is often influenced by the working fluid in a solar heating system. Thus, if air the heat transfer fluid used in a solar system then rock bed thermal storage is an obvious choice (Deffie and Beckman, 2006). If the primary working fluid is a liquid, then a liquid is usually used as a storage medium. It has been noted that water is an excellent storage medium for the low-to-medium temperature range because of its high volumetric heat capacity. El-Sabaii, *et al.* (2007) concluded that the thermal efficiency of solar collector with gravel is found to be higher than that without the packed bed by 22-27%. Gravel as a packed bed above the absorber plate during low intensity solar radiation periods is recommended. Dincer and dost (1996) reported that a solar system designer must seek answer to some basic questions about energy storage before proceeding with a project such as, “what types of storage are available?”, “how much storage is required”, “how will the inclusion of storage affect the system performance, reliability and cost”, “what storage system or designs are available. Johnson (1992) cited thick section of 20-30 cm are used when the sun shines directly on the material and thinner larger-area section of 10-15 cm are used when the sunlight in diffused within a space where storage, and release occurs from the same surfaces. The farm of animals have high hygiene requirements (DeVries *et al.* 2012, Josefsen *et al.* 2015) therefore water heating or preheating with ST systems can help to meet their high

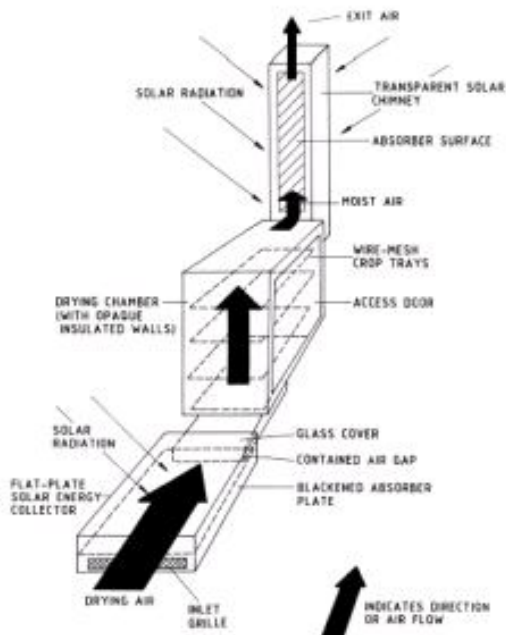

Fig 1: Typical distributed-type (indirect) natural-circulation solar energy (Ekechukwu and Norton, 1999)

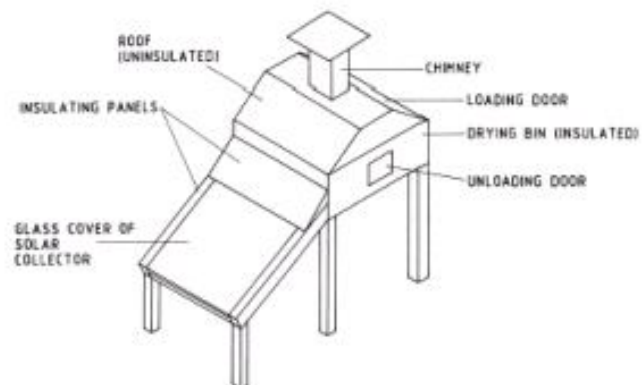

Fig 2: A distributed-type natural circulation solar maize dryer (Ekechukwu and Norton, 1999)

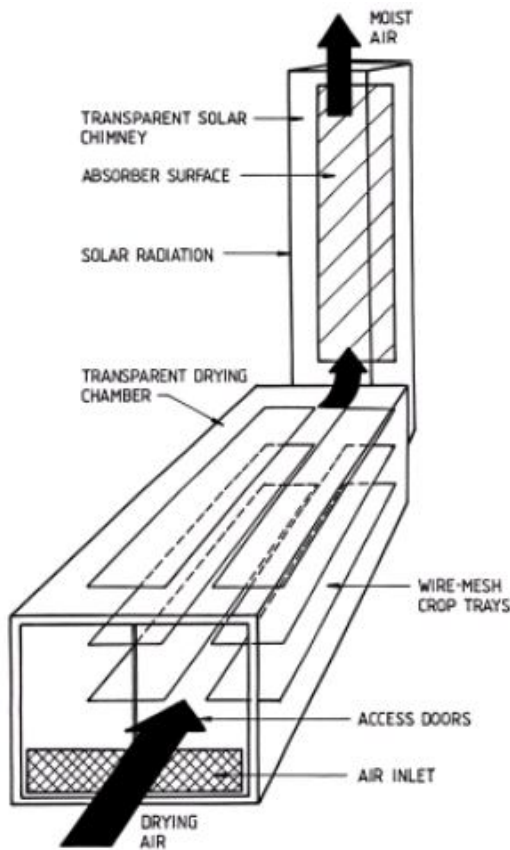

Fig. 3: Features of a typical integral-type (direct) natural-circulation solar-energy dryer (Ekechukwu and Norton, 1999)

water heating needs

Types of solar energy systems “Applications and Innovations”

1. Passive Solar Drying Systems

In the case of passive solar dryer, air is heated and circulated naturally; by buoyancy force, or a result of wind pressure or both. Normal and reverse absorber cabinet dryer and greenhouse dryer operates in passive mode. Passive drying of crops is common practice in many Mediterranean, tropical and subtropical regions, especially; in Asia and Africa or in small agricultural communities. These are primordial, frugal in construction with locally obtainable materials, effortless to install and to operate especially at sites far off from electrical grid. The passive dryers are best suited for drying small batches of fruits and vegetables such as banana, pineapple, mango, potato, carrots, etc (Hughes *et al.*, 2011).

2. Indirect-Type Passive Solar-Energy Dryers

These are indirect-kind dryers with natural convection of air for drying. In order to raise the capacity of a dryer which means; operate with more than one layer of trays with crops with an available area, trays are generally

placed in vertical racks with some space in between consecutive trays. The additional resistance generated for the air movement due to this arrangement of the trays is achieved by the “chimney effect”. The chimney effect increases the vertical flow of air as a result of the density difference of the air in the cabinet and atmosphere. Typical indirect passive solar-energy dryer used in crop drying are shown in Fig 1. Fig 2 shows the design by Ortho Grainger and Twidel (1981) for maize drying. The designs generally comprise of an air-heating solar-energy collector, an insulated ducting, a drying chamber and a chimney.

3. Direct-Type Passive Solar-Energy Dryers

The features of a typical direct-type passive solar dryer showed in Fig 3. In these kind of solar dryers the direct exposure of the crop to sunlight enhances, the color ripening desired in certain varieties of grapes, dates, coffee and development of full flavor in roasted beans. Two basic types of dryers in this category can be identified as the cabinet and greenhouse dryers.

3.1 Solar Cabinet Dryers

Passive solar cabinet dryers are commonly simple and inexpensive units having high applications for domestic purposes. They are suitable for drying of agricultural products, seasoning and herbs etc., constructed normally with a drying area of (1-2) and (10-20) kg capacities. Fig (4) showed a typical passive solar cabinet dryer. The heat for drying is transmitted through the glass cover and absorbed on the blackened interior and crops as well. The required air circulation is maintained by the warm moist air leaving by the upper vent under the action of buoyancy forces and generating suction of fresh air from the base inlet. Pioneering works on solar cabinet dryers were reported by the Brace Research Institute, (1980).

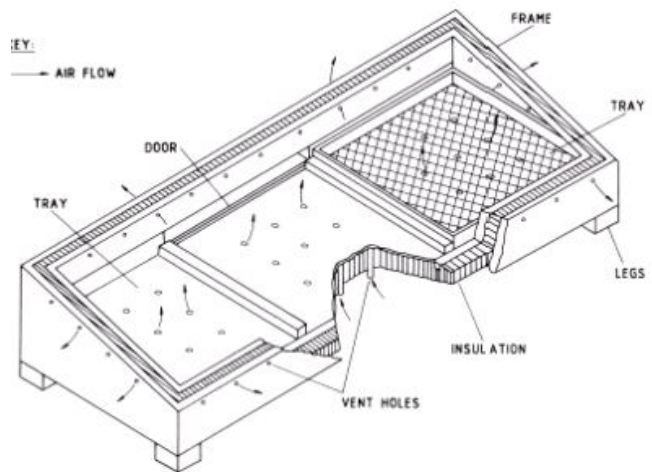

Fig. 4: A typical natural-circulation solar-energy cabinet dryer (Ekechukwu and Norton, 1999)

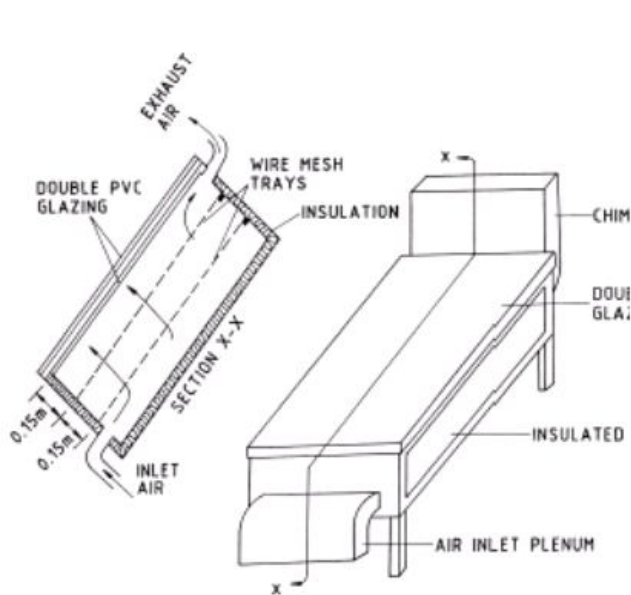

Fig. 5: A modified natural circulation solar-energy cabinet dryer (Ekechukwu and Norton, 1999)

Number of other designs of passive solar cabinet dryer in configuration to that developed by Brace Research Institute have been built and tested for a variety of crops and places. Ezekwe (1981) reported a modification of the typical design shown in Fig. 5 equipped with a wooden plenum guiding the air inlet and a long plywood chimney to enhance natural circulation, accelerating the drying rate by about 5 times over open sun drying. Fig. 6. showed the design by Henriksson and Gustafsson (1986), with mesh work floor and chimney with black (PVC) foil facing the southwards (sunlight). The passive solar cabinet dryer have a characteristic of being cheap and simple in construction from locally available material, however their main drawback is poor moist removal rates and very rising temperature (70-100°C) cause overheating of the product.

3. 2 Natural-Circulation Greenhouse Dryers

These are also called (tent dryers) and basically

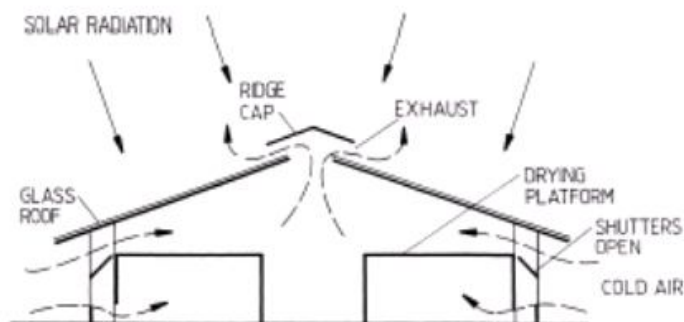

Fig. 7: Natural-circulation glass-roof solar-energy dryer (Ekechukwu and Norton, 1999)

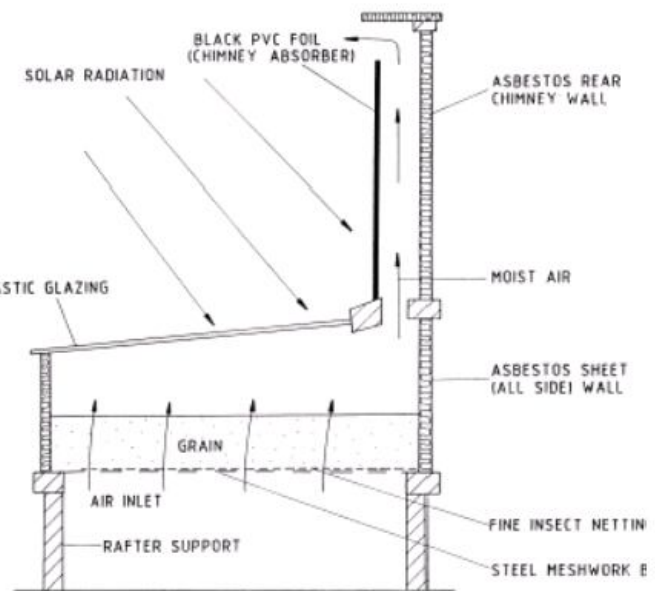

Fig. 6: A natural-circulation solar energy cabinet dryer with chimney (Ekechukwu and Norton, 1999)

modified greenhouses; they are designed with slots of appropriate size and position to control air flow. They are characterized by wide glazing through the transparent cover of polyethylene sheet. Fig. (7) Showed the earliest form of passive solar greenhouse dryer by the Brace Research Institute, with slanted glass roof, allowing direct solar radiation over the product. The length-wide north-south alignment of the dryer had black coated internals for improved absorption of solar radiation plus the ridge-cap over the roof for exit vent. Doe *et al.* (1977) then designed the widely reported poly-ethylene tent dryer, explicated in Fig. (8) Consisting of a ridged bamboo framework clad plus a clear polythene sheet over it. Black poly-ethylene sheet was also spread on the floor inside the tent to enhance the absorption of solar radiation. The air flow into the tent was controlled by rolling/ unrolling of the cladding at the bottom edge of front side and the

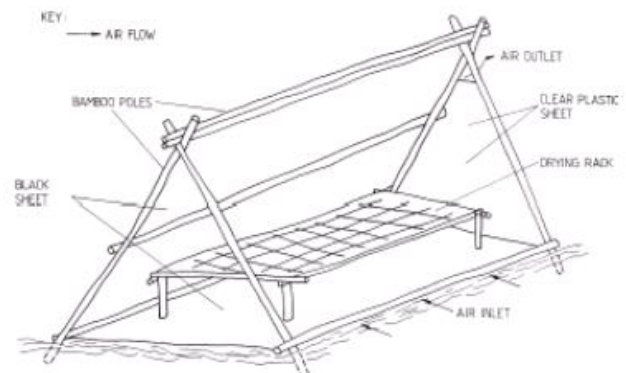

Fig. 8: Natural-circulation polythene-tent dryer (Ekechukwu and Norton, 1999)

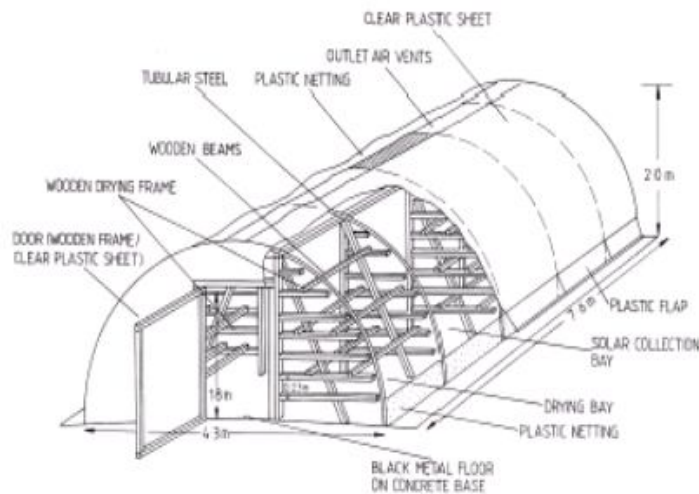

Fig. 9: Natural-circulation solar dome dryer (Ekechukwu and Norton, 1999)

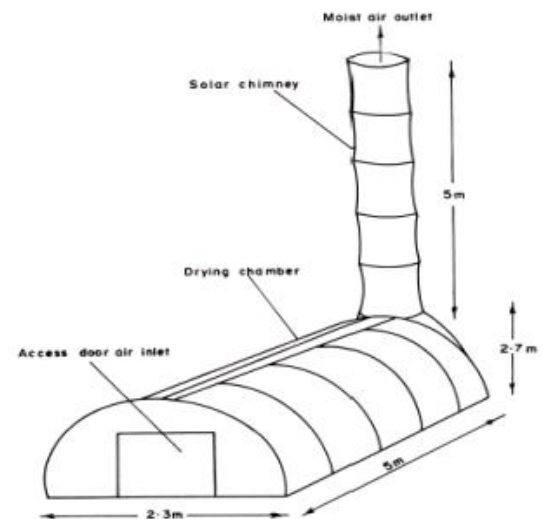

Fig. 10: A greenhouse type natural-circulation solar-energy dryer (Ekechukwu and Norton, 1999)

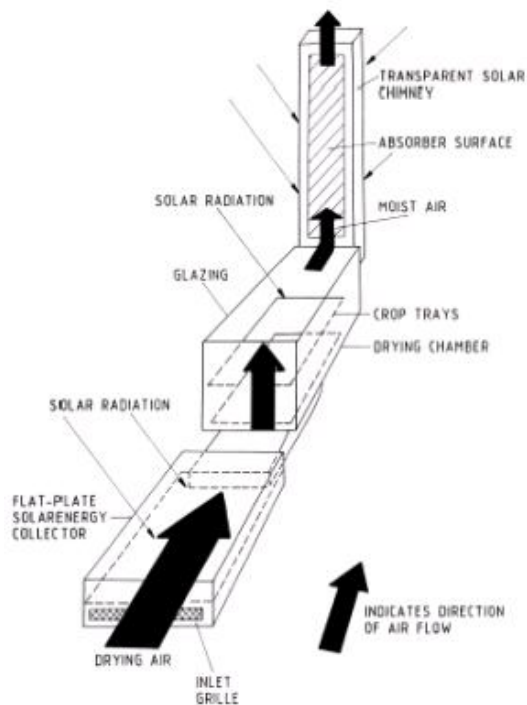

Fig. 11: Features of a typical mixed mode natural-circulation solar-energy dryer (Ekechukwu and Norton, 1999)

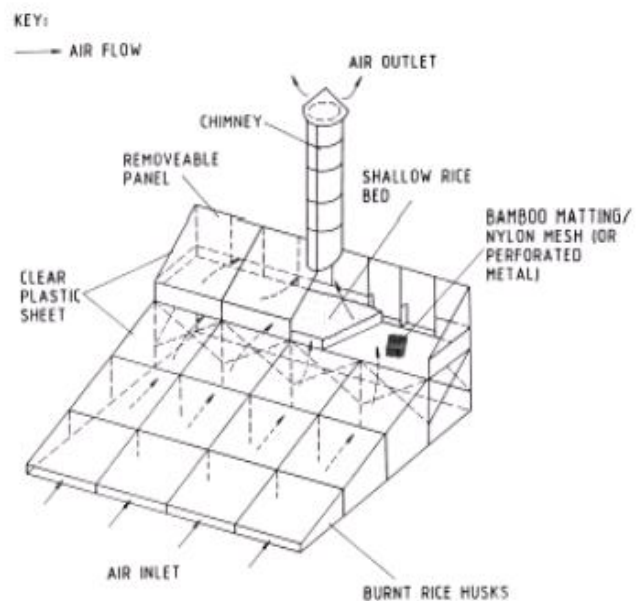

Fig. 12: A mixed-mode natural circulation solar rice dryer (Ekechukwu and Norton, 1999)

vents at the top served as the exit for the moist exhaust air. Sachithananthan *et al.* (1983) reported a horticultural greenhouse of clear plastic sheet cladding over a semi-cylindrical metal frame Fig. (9). The modification was with a black galvanized iron sheet absorber at floor, inlet vents along the full length of both sides of base and exit with plastic nets at the top to protect from insects and dust. Fleming *et al.* (1986) reported a typical greenhouse type solar dryer with a transparent semi-cylindrical chamber with a cylindrical solar chimney posted vertically

at one end and a door for air inlet and access to the chamber at other end as illustrate in Fig. (10). Rathore *et al.* (2010) has conducted various experimental studies on a modified design of hemi-cylindrical solar tunnel dryer for drying of grapes also few researchers (Jaijai *et al.*, 2011) used a polycarbonate cover for its construction. Afriyie *et al.* (2011) reported the study of simulation and optimization of a chimney ventilated solar crop dryer.

3.3.1 Hybrid-Type Passive Solar-Energy Dryers

Hybrid type passive solar-energy dryer would have

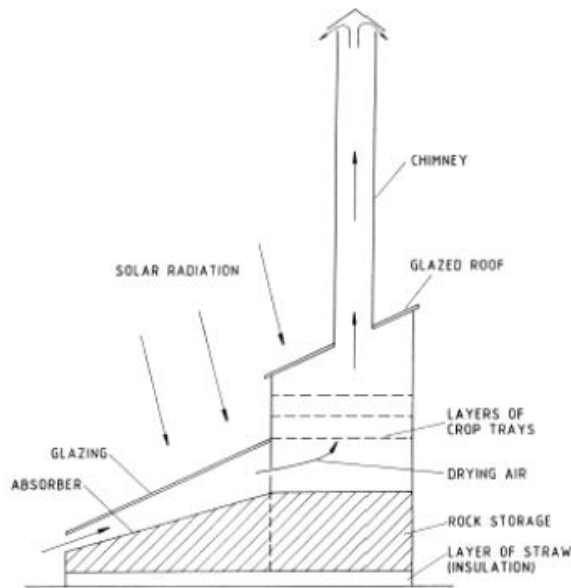

Fig. 13: A mixed-mode natural circulation solar-energy dryer with thermal storage (Ekechukwu and Norton, 1999)

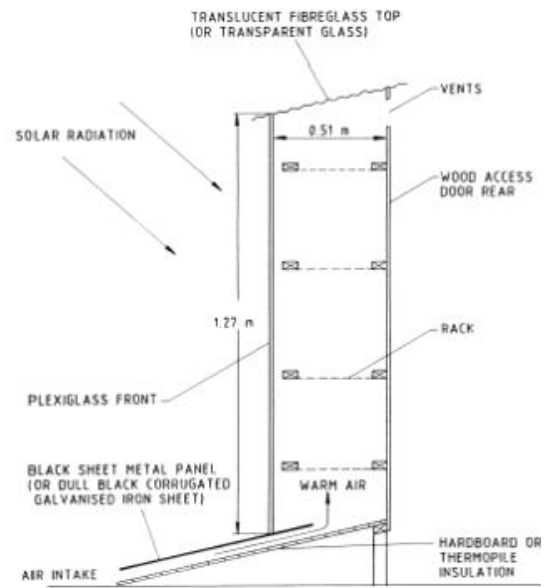

Fig. 14: A multi-stacked mixed mode natural circulation solar-energy dryer (Ekechukwu and Norton, 1999)

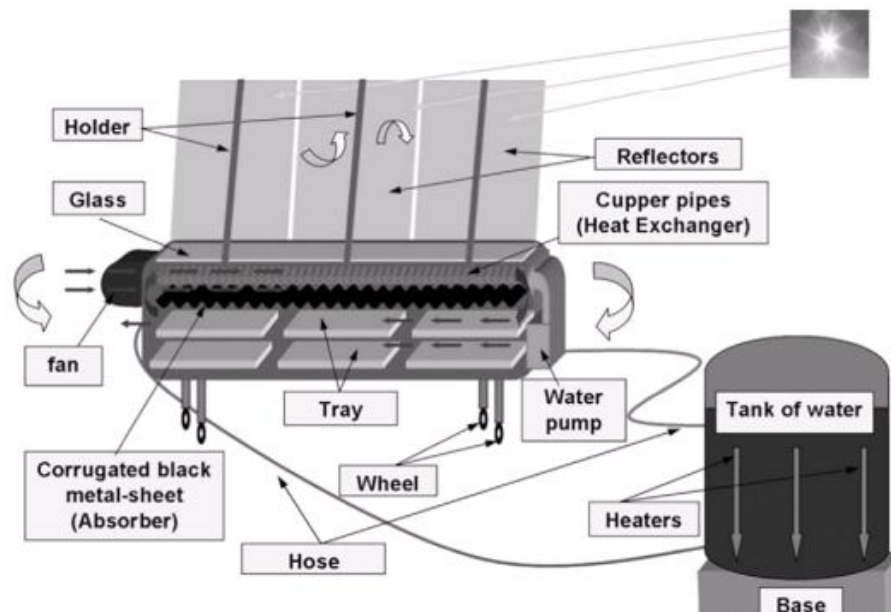

Fig. 15: Schematic diagram of a solar hybrid dryer (Amer *et al.*, 2010)

the same typical structural features as the indirect-type and direct-type (solar air heater, a separate drying chamber and a chimney), and in addition has glazed walls inside the drying chamber so that the solar radiation impinges directly on the product as in the direct-type dryers as shown in Fig (11). Exell *et al.* (1980), Sodha *et al.* (1987), at Asian Institute of Technology developed the widely reported solar rice dryer Fig (12). Ayensu and Asiedu (1986) designed the hybrid dryer consisting of an air heater with a pile of granite functioning as an absorber cum heat storage Fig (13). Sauliner first reported a multi stacked hybrid design different from that of Excel,

followed by Law and at Brace Research Institute also designed and tested by Sharma *et al.* (1986, 1987), as showed in fig (14). The multi-stacked design enables the simultaneous drying of a variety of crops. Several other designs of the hybrid-type passive solar energy have also been reported in (Amer *et al.*, 2010; Hughes *et al.*, 2011).

References

- Afriyie, J.K., H. Rajakaruna, M.A.A. Nazha and F.K. Forson (2011). Simulation and optimisation of the ventilation in a chimney-dependent solar crop dryer, *Solar Energy*, **85**: 1560-1573.

- Akachukwu, A.E. (1986). Solar kiln dryers for timber and agricultural crops. *Int. J. Ambient. Energy*, **7(2)**: 95-101.
- Aktas M, S. Sevik, A. Amini and A. Khanlari (2016). Analysis of drying of melon in a solar-heat recovery assisted infrared dryer. *Sol. Energy.*, **137**: 500–515.
- Amer, B.M.A., M.A. Hossain and K. Gottschalk (2010). Design and performance evaluation of a new hybrid solar dryer for banana. *Energy Conversion and Management*, **51**: 813-820.
- Ayensu, A. and V. Asiedu-Bondzie (1986). Solar drying with convective self-flow and energy storage. *Solar and Wind Technology*, **3(4)**: 273-279.
- Bena, B. and R.J. Fuller (2002). Natural convection solar dryer with biomass back-up heater, *Solar Energy*, **72 (1)**: 75–83.
- Brace Research Institute (1980). Types of solar agricultural dryers. *Sunworld*, **4(6)**: 181-999.
- Condori, M., R. Echazu and L. Saravia (2001). Solar drying of sweet pepper and garlic using the tunnel greenhouse dryer. *Renewable Energy*, **22**: 447–460.
- DeVries, T.J., M.G. Aarnoudse, H.W. Barkema, K.E. Leslie and M.A.G. von Keyserlingk (2012). Associations of dairy cow behavior, barn hygiene, cow hygiene, and risk of elevated somatic cell count. *J. Dairy Sci.*, **95(10)**: 5730–39.
- Dincer, I. and S. Dost (1996). “A perspective on thermal energy storage system for solar energy applications”. *International Journal of Energy Research*, **20**: 547-557.
- Doe, P. E., M. Ahmed, M. Muslemuddin and K.A. Sachithanathan (1977). A polythene tent dryer for improved sun drying of fish. *Food Tech. Aust.*; **29**: 437-441.
- Duansheng, C.; L. Buzhou.; N. Hemin.; Z. Haishan.; Z. Jiangou.; and T. Quan (1991). Technology of the energy- saving sunlight greenhouses in china”. The proceeding of international symposium on applied Technology of greenhouses, pp: 41-49.
- Duffie, J.A. and W.R. Backman (2006). Solar engineering for thermal processes. 3th ed. Pp. 907. John Wiley and Sons.
- Ekechukwu, O.V. and B. Norton (1999). Review of solar energy drying system II: an overview of solar drying technology. *Energy Convers Manage*; **40**: 615–55.
- Ekechukwu, O.V. (1999). Review of solar-energy drying systems I: an overview of drying principles and theory. *Energy Conversion and Management*, **40**: 593–613.
- El-Sebaili A.A., S. Aboul-Enein; M.R.I. Ramadau and E. El-Bialy (2007). Year round performance of double pass solar air heating with packed bed. *Energy Conversion and Management*, **48**: 990-1003.
- Esper, A. and W. Muhlbauer (1998). Solar drying – an effective means of food preservation. *Renew Energy*, **15**: 95–100.
- Exell, R.H. B. (1980b). A simple solar rice dryer- basic design theory. *Sunworld*, **4(6)**: 186-190.
- Ezekwe, C.I. (1981). Crop drying with solar air heaters in tropical Nigeria, ISES, Solar World Forum, Brighton, UK, Pergamon Press, Oxford, pp. 997-1005.
- Fleming, P.D., B. Norton, O.V. Ekechukwu, S.O. Onyegegbu and S.D. Probert (1986). A large-scale facility for experimental studies of natural-circulation solar-energy tropical crop dryers. In: ProcInt Drying Symp (Drying '86). Cambridge, Mass., U.S.A., Hemisphere Pub Coy Washington, pp. 685-693.
- Gemea, G.R., A.T. Taha and M.H. Keshek (2012). Thermal performance of solar energy storage in some solid materials. *Misr. J. Agric. Eng.*, **29(1)**: 429-350.
- Ghoniem, E.Y. and R.R. Gemea (2014). Design and evaluation of an enhanced solar dryer using heat storage unite for tomatoes drying. *Misr. J. Agric. Eng.*, **31(3)**:1025-1046.
- Gil, A., M. Medrano, I. Martorell, A. L. Zaro, P. Dolado, B. Zalba and L.F. Cabeza (2010). “State of the art on high temperature thermal energy storage for power generation. Part I concepts, materials and moldellization”. *Renewable and Sustainable Energy Reviews*, **14**: 31-55.
- Grainger, W., H. Othieno and J.W. Twidel (1981). Small scale solar crop dryers for tropical village use-theory and practical experiences, ISES, Solar World Forum, Brighton, UK, Pergamon Press, Oxford, pp. 989-96.
- Gulcimen, F., H. Karakaya and A. Durmus (2016). Drying of sweet basil with solar air collectors. *Renew. Energy*, **93**: 77–86.
- Henriksson, R. and Gustafsson (1986). Use of solar collectors for drying agricultural crops and for heating farm buildings. *Energy in Agriculture*, **5**: 139-150.
- Huang, B.K. and M. Toksoy (1981). Greenhouse solar system for selective year-round solar-energy utilization in agricultural production. *Agric Energy*, pp. 1-152.
- Hughes, B.R. and M. Oates (2011). Performance investigation of a passive solar-assisted kiln in the United Kingdom, *Solar Energy*, **85**: 1488-1498.
- Janjai, S., P. Intawee, J. Kaewkiew, C. Sritus and V. Khamvongsa (2011). A large-scale solar greenhouse dryer using polycarbonate cover. *Renewable Energy*, **36**: 1053- 1062.
- Johnson, R.W. (1992). Analytical results for specific system. Passive solar building. The MIT Pres, Cambridge, Massachusnets, London.
- Josefsen, M.H., A.K. Bhunia, E.O. Engvall, M.S.R. Fachmann and J. Hoorfar (2015). Monitoring Campylobacter in the poultry production chain - From culture to genes and beyond. *J. Microbiol. Methods*, **112**: 118–25.
- Kant, K., A. Shukla, A. Sharma, A. Kumar and A. Jain (2016). Thermal energy storage based solar drying systems: A review. *Innov. Food Sci. Emerg. Technol.*, **34**: 86–99.
- Kapica, J. (2017). Storage systems for solar energy suitable for agriculture Part one: thermal energy. *Econtechmod. an International Quarterly Journal*, **6(4)**: 55–62.
- Misha, S., S. Mat, M.H. Ruslan, E. Salleh and K. Sopian (2016). Performance of a solar-assisted solid desiccant dryer for

- oil palm fronds drying. *Sol. Energy*, **132**: 415–29.
- Müller, J., M. El-Shiatry and W. Mühlbauer (1991). Drying fruits and vegetables with solar energy in Egypt. *Agric. Mech. Asia Africa Latin Am.*; **22(4)**:61–4.
- Ozturk H.H. and A. Bascetincelik (2003). Energy and exergy efficiency of a packed bed heat storage unite for greenhouses heating. *Biosyst Eng.*, **86(2)**: 231-45.
- Rathore, N.S. and N.L. Panwar (2010). Experimental studies on hemi cylindrical walk-in type solar tunnel dryer for grape drying. *Applied Energy*, **87**: 2764-2767.
- Sachithananthan, K., D. Trim and C.I. Speirs (1983). A solar dome dryer for drying of fish, FAO Fisheries Paper, Rome, Italy.RAB/81/002/INT/L8.
- Sharma, S., R.A. Ray and K. Sharma (1987). Comparative study of solar dryers for crop drying. *Invention Intelligence*, **22**: 105-113.
- Sharma, V.K., S. Sharma, R.A. Ray and H.P. Garg (1986). Design and performance studies of a solar dryer suitable for rural application. *Energy Conversion and Management*, **26**: 111-119.
- Slama, R.B. and M. Combarous (2011). Study of orange peels dryings kinetics and development of a solar dryer by forced convection. *Solar Energy*, **85**: 570-578.
- Sodha, M.S., N.K. Bansal, K. Kumar, P.K. Bansal and M.A.S. Malik (1987). *Solar Crop Drying 1*, West Palm Beach, CRC Press.
- Trim, D.S. and H.Y. Ko (1982). Development of a forced-convection solar dryer for red peppers, *Tropical Agriculture (Trinidad)*, **59(4)**: 319-323.
- Ziaforoughi, A. and J.A. Esfahani (2016). A salient reduction of energy consumption and drying time in a novel PV-solar collector-assisted intermittent infrared dryer. *Sol. Energy*, **136**: 428–36.